

ABEL SH

From the reciprocating positive displacement pump specialist



**Solids Handling Pumps for
difficult media at high pressure**

ABEL SH - Performance range: up to 103 m³/h (450 GPM); up to 16.0 MPa (2,300 psi)

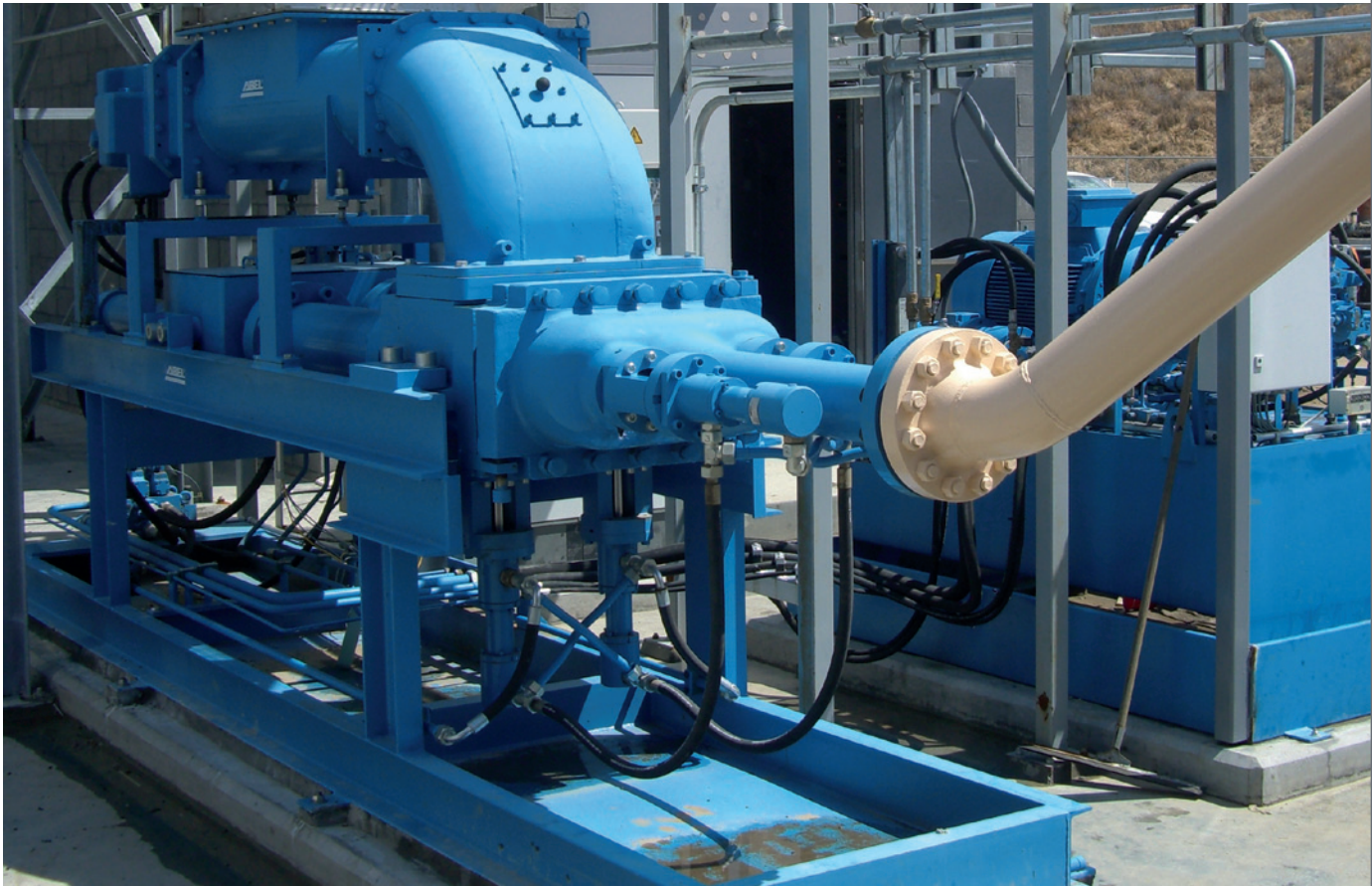

ABEL SH with double screw feeder for transfer of dewatered sewage sludges

ABEL SH SOLIDS HANDLING PUMPS span a wide performance range and are suited for a large number of pumping media and applications. These high pressure pumps really prove their worth when extremely abrasive, paste-like and compact media (e.g. dewatered sewage sludge) have to be conveyed safely at high pressure.

At ABEL, this high-capacity pump has extra wall thickness and large suction valves, which, when combined with the very good filling efficiency, produce a service life that is longer than the norm.

Along with the actual pump unit (consisting of sludge, hydraulic main and valve cylinders) an ABEL SH solids handling pump comprises a total of four components: the actual pump, the hydraulic drive unit, a screw feeder to fill the product cylinder, and a control cabinet with PLC.

The programmable logic controller is the “brain” of the system and allows for integration with complex processes and control room systems.



Original ABEL spare parts ensure availability of your installation

Applications of the ABEL SH

- For the transfer of dewatered sludge or filter cakes from
 - Industry and municipalities
 - Centrifuges, chamber filter presses, vacuum presses, and belt presses
- Feeding incinerators with dewatered and pre-dried sludge, hazardous waste, chemical residues, and solvents
- In mining, for backfilling and transporting paste-like mine slurry

 Available with ATEX certification.

The Design Advantages

- Duplex piston pump with hydraulically-actuated cone valves – short-circuit free, even at high pressures
- Cone valves with elongated valve rods – safe protection against cross-contamination of the hydraulic circuit with the pumped media
- Electrical pump control as standard with modern PLC for local or external parameters, e.g. incinerator temperature control
- Capable of running dry
- Enclosed pipeline transfer
- Fully automatic, efficient disposal and feed operations

Optimized filling efficiency

Odorless, environmentally beneficial and cost-saving:
Front feeder for enclosed pipeline transfer

Suction stroke

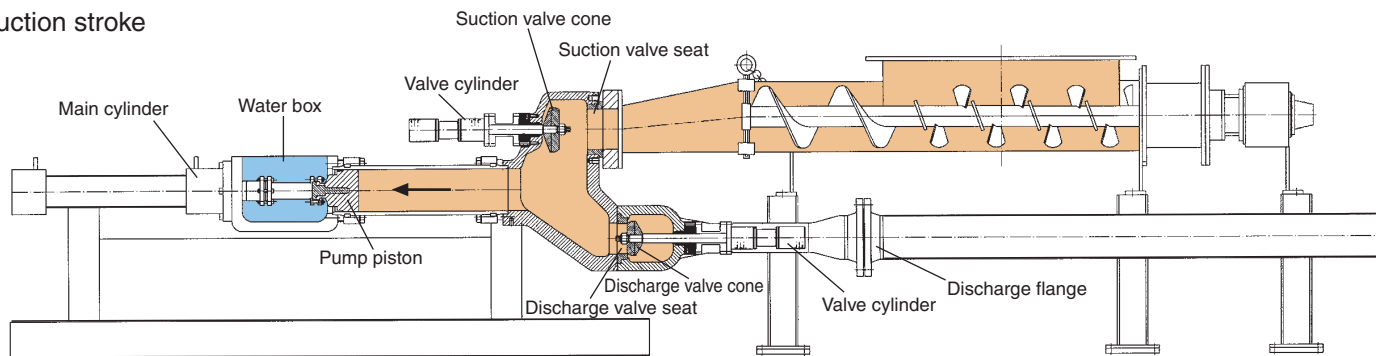

Discharge stroke

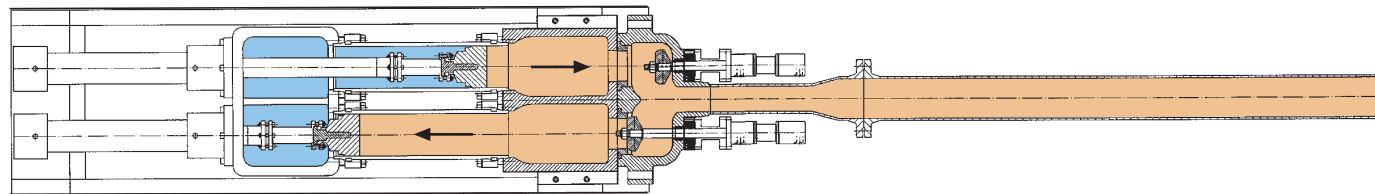
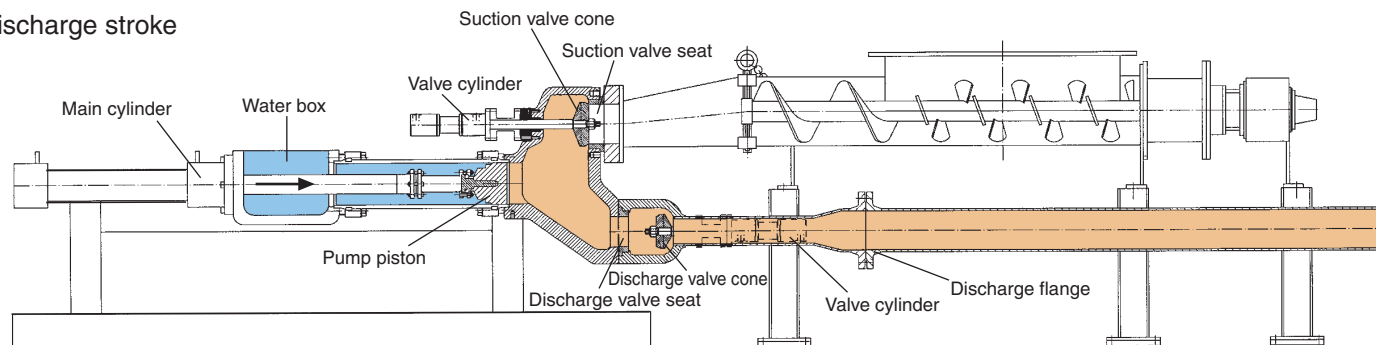

Function principle using the example of the ABEL front feeder. The pump piston draws the medium into the pump cylinder. When the piston reaches its end position, the suction valve closes and the discharge valve opens. Then the pump piston begins its discharge stroke and pushes the medium into the discharge line.

Advantages of the front feeder

With this solution, the pump cylinders are filled directly, which means:

- No unnecessary directional changes
- No clogging of the pump cylinders
- Maximum filling and pumping efficiency

Since the performance of a Solids Handling Pump depends considerably on how efficiently the pump is filled, ABEL has designed a new 'front-loading feed' system. This is especially useful for sludges/cakes with high dry solids content.

Pumping medium is fed by a double screw feeder into the ABEL Solids Handling Pump. With minimal directional change ($< 32^\circ$), it enters the pump through an open, hydraulically actuated suction valve.

The suction side valve rods are not located in the line of the flow, so a maximum through-flow of medium is assured during a discharge stroke.

Complete Automation with PLC for Central Control Systems

The "brain" of the unit (control cabinet with PLC) controls the integration into complex processes and central control rooms. Various external control parameters like incinerator temperature or silo filling levels can be used as input signals for the PLC. The capacities of pump and feed device are automatically adjusted to ensure a maximum operational efficiency.

ABEL has supplied numerous custom made systems to fulfill the critical needs of customers.



Dewatered sewage sludge with 35 % solids content- no problem for an ABEL solids handling pump



Even paste-like sludges can be pumped with ABEL solids handling pumps

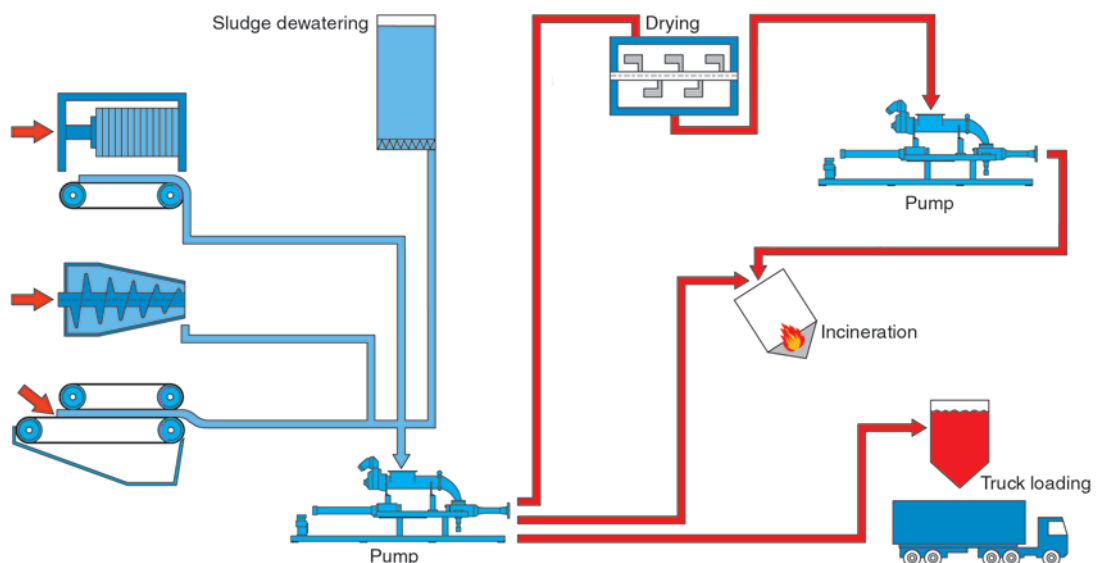

For solids concentration up to 35 %

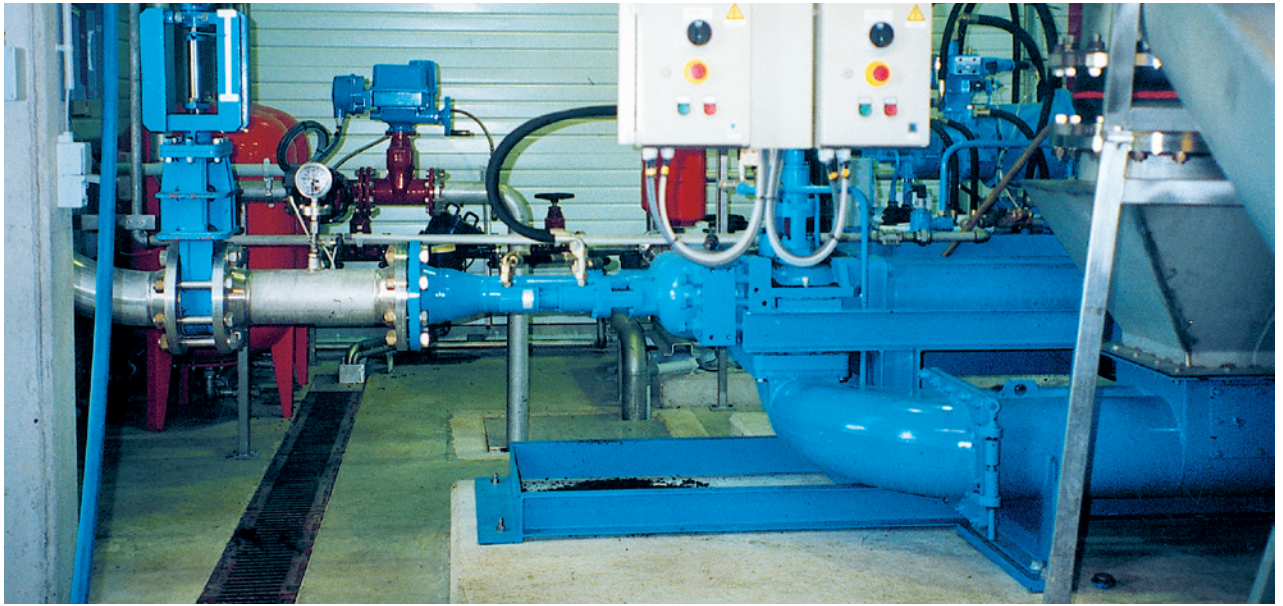

Typical application of an ABEL SH pump: Transfer of dewatered sewage sludge, here on a waste water treatment plant in Belgium

ABEL SH for Temperatures up to 200 °C (400 °F)

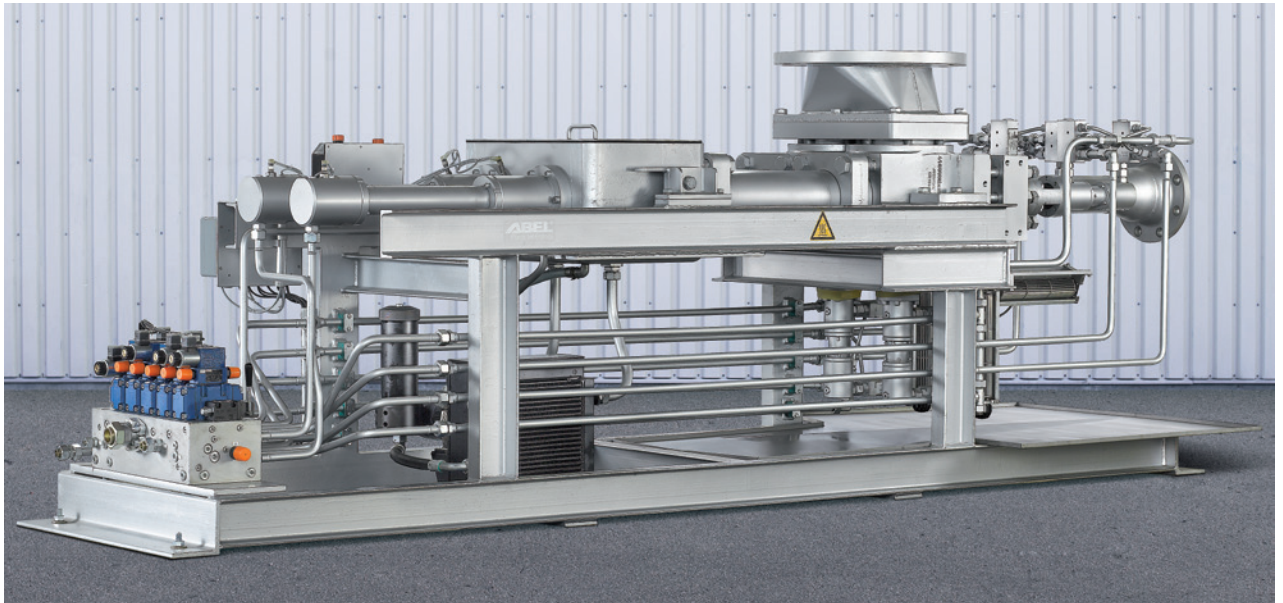

High temperature design of an ABEL SH as reactor feed pump for highly heated biomass

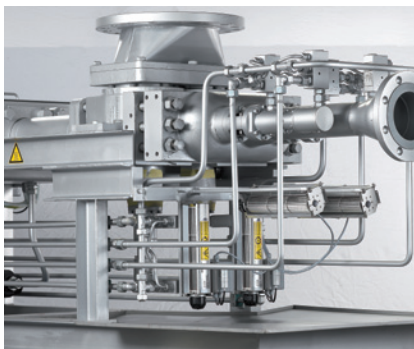

Individually actuated, separately cooled cone valves

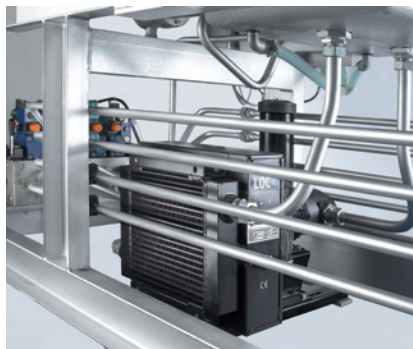

Additional air cooler for the hydraulic buffer fluid



Tangential blowers to cool valve cylinders



Membrane Pumps
Solids Handling Pumps
High Pressure Pumps
Marine Pumps

For North America

ABEL Pumps L.P.
79 N. Industrial Park, Overlook Drive
Sewickley, PA 15143-2339, USA
Phone +1 (412) 741 3222
Fax +1 (412) 741 2599
mail@abelpumps.com

For Spain, Portugal, Central and South America

ABEL Equipos S.A.
C/Anochecer 2, Edificio el Torreón
28223 Pozuelo de Alarcón, Spain
Phone +34 (91) 715 4848
Fax +34 (91) 799 0017
mail@abelequipos.es

ABEL GmbH & Co. KG
Abel-Twiete 1
D - 21514 Büchen, Germany

Phone +49 (4155) 818-0
Fax +49 (4155) 818-499
mail@abel.de • www.abel.de