

## ABEL EM

From the reciprocating positive displacement pump specialist



## Electromechanical Membrane Pumps

The economical alternative

## ABEL EM - Performance ranges up to 120 m<sup>3</sup>/h (530 GPM), up to 0.8 MPa (120 psi)



ABEL EM in a municipal WWTP – often the more economical alternative to transfer sludges with fibrous content

### Several versions. One idea.

ABEL EM is available in several basic versions and a total of 50 combinations to meet the requirements of the wide range of applications. This is supplemented by a great variety of materials for diaphragms (membranes), balls and valve seats.

#### ABEL EM Metal

#### ABEL EM Plastic

A convincing alternative to conventional pump technology for numerous applications.

**THE ADVANCE OF DESIGN.** This robust pump technology is especially advantageous for many applications that require low pressure. The ABEL EM is a mechanically driven diaphragm pump that is highly energy efficient, because the drive does not require expensive compressed air. Its compact, special design does not require hydraulic fluid, and it can be suitably equipped to provide the performance required by each specific application.

The ABEL Electromechanical Diaphragm Pump's unique design concept and impressively low energy consumption when used in the most diverse of applications by the most demanding of customers have helped solidify the excellent reputation of ABEL.

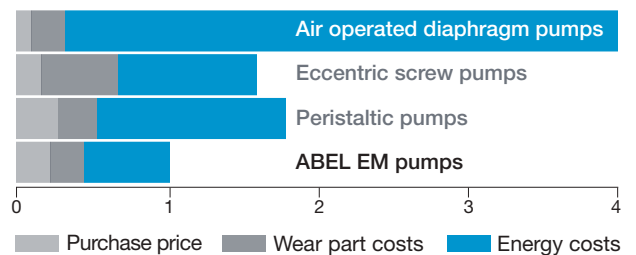

### Reduced life cycle cost

The patented Electromechanical Diaphragm Pump, is recognized as the world market leader in its class. The use of conventional pumps in a range up to 120 PSI often incurs high operating costs. Purchase cost is only a fraction of the total life cycle cost of a pump (see the graph illustration).

### Specialization creates Know-how

The EM series pump technology of ABEL is unique. It is a field proven replacement, and first choice alternative serving a diverse range of critical customer needs in process and transfer applications.

The EM series pumps incorporate the sealless, dry-running, low shear, versatile fluid handling capability of traditional diaphragm pump design with added value including:

- Highly efficient electric drive
- Constant flow rates against variable pressure and viscosity
- Up to 6" Port size for maximum flow rate
- Fully enclosed diaphragms - with no material exposure
- Optional VFD flow control for true process performance
- Optional pulsation dampeners and other accessories

The EM series is also a viable alternative for expensive, sometimes space-consuming pump technologies for which the continuing cycle of maintenance costs can far exceed the original cost of the pump.

Viscous, solids-containing, aggressive, and/or corrosive fluids have been less a source of concern for those who commonly return to ABEL for their challenging applications. One reason is ABEL's "Know-How" as much as product reliability.

Powder transfer with the EM Series is also available to simplify transfer of powders that "fluidize."

### The advantages of ABEL EM

- Smooth product transfer
- Low operating costs through high efficiency
- Almost constant flow rate across the whole pressure range; i.e. maximum capacity even with changing viscosities
- High reliability because safe against dry running
- Comfortable operation
- Variable flow rate from 0 to 100%
- Long life through robust design
- Flexible application through variable materials

### Design

The EM pump series are all electromechanical double-acting diaphragm pumps of robust process construction. The integral metal core of each diaphragm is completely covered by the diaphragm material on its fluid pumping side, minimizing the possibility of fluid contamination.

The smooth mechanically controlled linear drive of the diaphragms ensures low shear, seal-less, positive displacement performance with controlled transfer rates through variable viscosity and system pressure changes. Variable flow control is realized through a variable frequency drive (VFD) as a stand-alone device or controlled by customer system controls. Alternatively mechanical speed devices can provide for a range of variable flow.

Maximum discharge pressure can be limited by an external electrical control device, such as, a pressure switch or contact making pressure gauge when required for additional protection.

Optional discharge dampeners and suction stabilizers are available to minimize flow pulsations under variable or demanding system conditions that would otherwise decrease performance and/or operating life of the equipment. These dampeners are also available in self-adjusting "intelligent" executive.

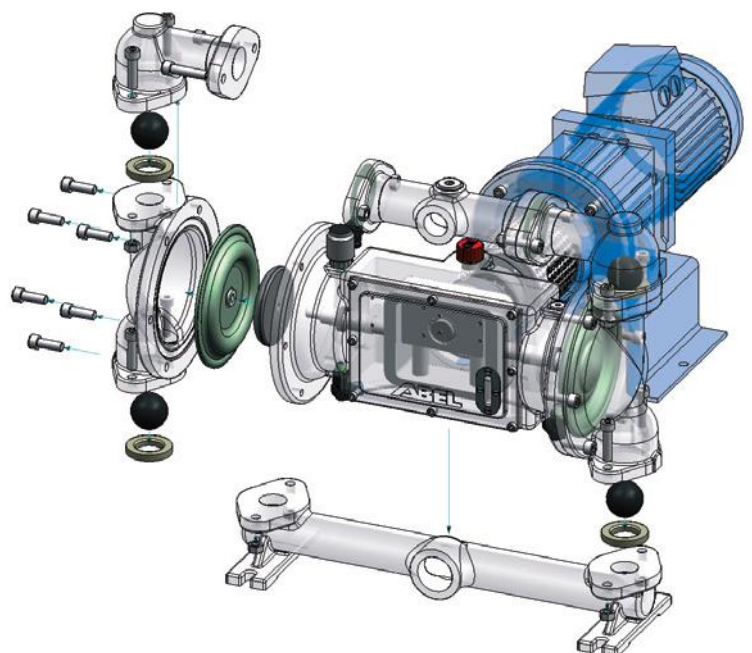

## ABEL EM Metal

Long life through robust design



Performance ranges up to 120 m<sup>3</sup>/h (530 GPM), up to 0.8 MPa (120 psi)\*

### Robust housing construction:

- Ductile Iron (SG)
- Stainless Steel (ED)
- Aluminum (AL) (Contact ABEL)

### Diaphragm/ball/seat options:

- BUNA-N/NBR
- EPDM
- polyurethane (only balls and seats)
- FPM (Viton®)
- PTFE
- flap valves to handle larger solids



ATEX design available

## ABEL EM Plastic

For aggressive media



Performance ranges up to 20 m<sup>3</sup>/h (90 GPM), up to 0.8 MPa (120 psi)\*

In the chemical industry and in other areas of process technology aggressive media require the use of high-quality plastics such as polypropylene (PP) or PVDF (PV) as well as explosion proof motors. ABEL delivers suitable pumps for these applications with flow rates up to max. 20 m<sup>3</sup>/h (90 GPM).

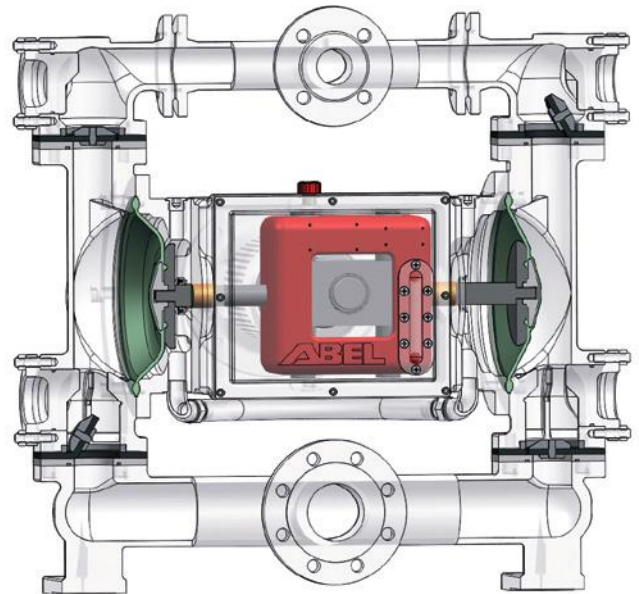

### The EM accessory program

To meet your demands: ABEL Accessories like pulsation dampeners, pressure monitoring devices and variable frequency drives (VFD) allow reasonable options for measurement, control and optimum process adaption for individual applications.

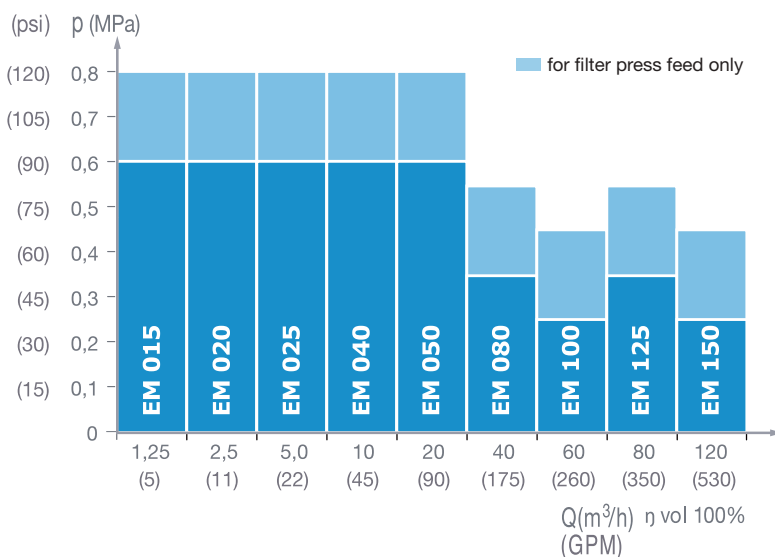

\* depending upon pump size and application

## ABEL EM – Two versions. One Basic Idea.

### Used as process and transfer pumps for

- sludge
- slurries
- chemicals
- waster water
- powder
- suspensions

### Industries

- chemical industry
- waste water treatment plants
- ceramic
- mining
- power plants
- paint and coatings
- pulp & paper
- refineries
- food processing

### ABEL-Pumps + ATEX-Directive 94/9/EC

Pumps by ABEL transport difficult media in a gentle and secure manner. They are as suitable for aggressive, abrasive, and highly inflammable fluids as for media of high viscosity. The Electromechanical Diaphragm Pumps of the EM series (Z version) are available with ATEX certification for the equipment group II, categories 2 and 3.

We have paid particular attention to the potentially different zones on the inside and on the outside of the pump. Depending on the application and the place of installation, it is possible that the inside of the pump exhibits an Ex zone that differs from the requirement the operator has determined for the respective place of installation. The application of ATEX requires the existence of atmospheric conditions. As a result, the assumed continuous existence of a pressure above the atmospheric pressure within the pump would counter the specific safety requirements of ATEX.

The definitions show that only the operator (inspector, customer) can determine as to whether an area where the pump is to be installed constitutes a potentially explosive atmosphere and/or as to whether a potentially explosive mixture can form. However, in many cases, this evaluation is extremely difficult even for the operator.

For that reason, we aim to provide our customers with comprehensive support with regard to all questions related to ATEX.



EM-050-PP for transfer of acidic waste water in the chemical industry



Quadruple diaphragm pump EM-125



ABEL EM Pumps in a rough continuous use



Membrane Pumps  
Solids Handling Pumps  
High Pressure Pumps  
Marine Pumps

For North America

ABEL Pumps L.P.  
79 N. Industrial Park, Overlook Drive  
Sewickley, PA 15143-2339, USA  
Phone +1 (412) 741 3222  
Fax +1 (412) 741 2599  
mail@abelpumps.com

For Spain, Portugal, Central and South America

ABEL Equipos S.A.  
C/Anochecer 2, Edificio el Torreón  
28223 Pozuelo de Alarcón, Spain  
Phone +34 (91) 715 4848  
Fax +34 (91) 799 0017  
mail@abelequipos.es

**ABEL GmbH & Co. KG**  
Abel-Twiete 1  
D - 21514 Büchen, Germany

Phone +49 (4155) 818-0  
Fax +49 (4155) 818-499  
mail@abel.de • www.abel.de